



The Arecont Vision 4 inch dome offers excellent protection for the wide variety of Arecont Vision mini megapixel cameras.

The combination of superior imaging and the 4 inch dome provide a perfect solution to environments in which cameras need to be less noticeable or require additional protection from the elements

- Indoor or Outdoor Applications
- Surface Mounting
- Simple Installation
- IP66 Rating
- “Triple Gimbal” Mount for Precise Camera Adjustment
- Designed to House the Entire Line of Day/Night Megapixel Cameras



**VANDAL RESISTANT :** Tough, high-impact polycarbonate construction with a heavy duty enclosure for harsh environments.

**FULL VIEW IN ALL DIRECTIONS:** Camera can be rotated a full 360° horizontally and 0-90° vertically, allowing full flexibility for either ceiling or wall mounting. Dome will ensure outstanding observation with excellent color sensitivity and high resolution for the Arecont Vision line of mini megapixel cameras.

**EASY INSTALLATION:** Easy installation, superior design for indoor or outdoor usage.



## MODEL NUMBER

### Dome 4-I

Indoor/Outdoor vandal resistant dome

## MECHANICAL

### Housing material:

Aluminum

### Dome Cover Protection:

Vandal resistant polycarbonate

### Dome Cover Diameter:

4.5 inch (114.3 mm)

### Back Plate Diameter:

6.30 inch (160 mm)

### Housing Height:

4.90 inch (125 mm)

### Dome Cover Height:

2.80 inch (70 mm)

### Housing Diameter:

6.30 inch (160 mm)

### Weight w/o camera:

2.2lbs(1kg)

### Security:

Tamper proof screws

### Compatible Cameras:

AV1300M, AV2100M, AV3130 M, AV3100M, AV5100M

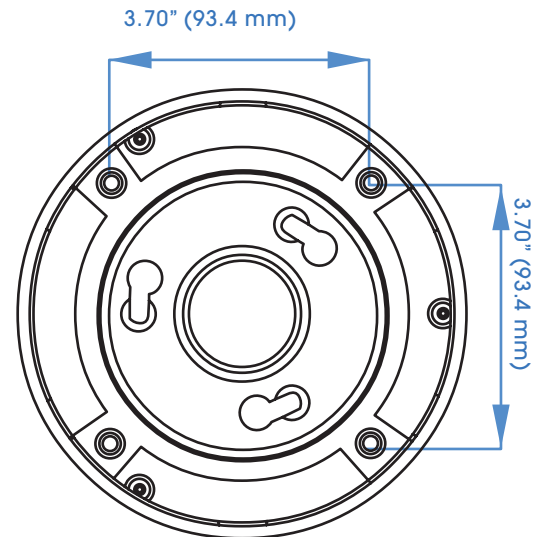
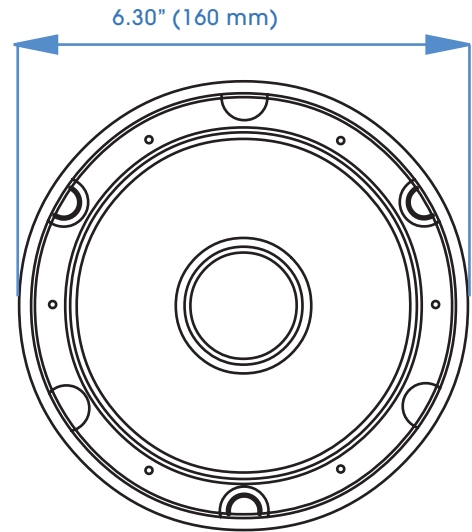

## ENVIRONMENTAL

### Operating Temperature:

0°C to 50°C

### Humidity:

0 to 95 % relative, non-condensing

### Enclosure Protection:

IP66 Rating

